

MAINTENANCE AND LUBRICATION

LIBRICATION GUIDE

Check and lubricated all components at the interval outlined in the periodic maintenance chart beginning in page45. iterns not listed in the chart should be lubricated at the general lubrication interval.

Lubrication guide key

- ▶ Move often under severe use.
- ★ premium ALL SEASON GREASE or grease conforming to NLGI NO.2, such as conoco superlube M or mobilegrease special
- Use Premium U-joint Lube every 500 miles, before long period of storage, or after pressure washing or submerging.

LTEM	LUBE	Method
Engine Oil	Premium 4 Synthetic ow40	Add to proper level on dip-stick
Brake fluid	DOT 3 Only	Maintain level between fill lines
Transmission Oil	Premium AGL Synthetic Gearcase Lube	A detailed reading instruction or contact with dealers
Front Gearcase Oil	Premium Demand Drive Hub Fluid	A detailed reading instruction or contact with dealers
Rear Gearcase Oil	Premium TTV Angle Drive Fluid	A detailed reading instruction or contact with dealers
Front Prop Shaft Yoke(Fig.1)	Grease	Grease fittings(3 pumps maximum)
Ball Joint (Fig.2)	Grease	Locate fitting on back side of struts and grease with grease gun

MAINTENANCE AND LUBRICATION

Premium 4 synthetic lubricant

Premium 4 All Season synthetic engine oil has been specially formulated for use in 4-cycle engines. It's a fully synthetic, high performance, multi-viscosity oil designed to provide the ultimate in lubrication performance and protection.

Note:

Premium 4 possesses unsurpassed film strength over the widest possible temperature range. It resists viscosity and frictional breakdown in ambient temperatures from -40° F. to 120° F. (-40 to =49° C.) Its exceptional frictional properties result in more efficient operation, more power output and lower fuel consumption.

Although Premium 4 is the only oil recommended for use in this engine, use of any API certified SH oil is allowable as long as it's OW-40. Oil may need to be changed more frequently if Premium 4 is not used. Follow the manufacturer's recommendations for ambient temperature operation.

CAUTION

Mixing brands or using non-recommended oil may cause serious engine damage. We recommend the use of Premium 4 synthetic Oil or another OW-40 API certified SH oil. Never substitute or mix oil brands.

MAINTENANCE AND LUBRICATION

Oil check

The oil dipstick and fill tube are located on the left side of the ATV.

Note: a rising oil level between checks in cool weather driving can indicate contaminants such as gas or moisture collecting in the crankcase. If the oil is over the full/ safe mark, change the oil immediately

1. Position the ATV on a level surface.
2. Start the engine and let it idle for 20–30 seconds.
3. Stop the engine. Remove the dipstick and wipe it dry with a clean cloth.
Note: if the dipstick is equipped with a lever lock , lift the lock to remove the dipstick.
4. Reinstall the dipstick completely, but do not lock it (if equipped). The dipstick must be completely seated to keep the angle and depth of the stick consistent.
5. Remove the dipstick and check the oil level. Maintain the oil level in the normal or safe range , depending on the style of dipstick in your model. Do not overfill.
6. After reinstalling the dipstick, be sure to seat the lever lock (if equipped).

Oil and filter change

Change the oil and filter at the intervals outlined in the Periodic Maintenance Chart beginning on page 45.

Oil change

- 1.1. Position the vehicle on a level surface. Clean the area around the drain plug at the bottom of the oil tank and the bottom of the engine.
2. Run the engine for two to three minutes, then turn it off.
3. Place a drain pan beneath the oil tank and remove the drain plug. Allow the oil to drain completely.
4. Install a new sealing washer on the oil drain plug.
Note: the sealing surfaces on the drain plug and the oil tank should be clean and free of burrs, nicks or scratches.
5. Reinstall the drain plug and torque to 14–17 ft. lbs. (19–23 Nm)
6. Disconnect the lower oil delivery hose and remove the screen fitting from the oil tank. Clean and reinstall the fitting, torquing to 25 ft. lbs. reattach the oil line.
Note: the fitting threads must be sealed with loctite™ PST 505 OR PTFE seal tape. The fitting must also line up with the mark on the rear side of the oil tank.

MAINTENANCE AND LUBRICATION

Oil change

7. Place shop towels beneath the oil filter. Using an oil filter wrench, turn the filter (1) counterclockwise and remove. .

8. Lubricate the gasket on the new filter with a film of new engine oil. Check to make sure the gasket is in good condition. Also make sure the gasket from the old filter is not still on the engine.

9. Install the new filter and tighten by hand 1/2 to 3/4 turn after gasket contacts the engine.

10. Approximately one cup of engine oil will remain in the crankcase. To drain, remove the drain plug on the lower right side of the crankcase.

Note: the sealing surfaces on the drain plug and crankcase should be clean and free of burrs, nicks or scratches.

11. Reinstall the drain plug and torque to 14 ft. lbs (19 Nm).

12. Remove the dipstick and add two quarts (1.9.1) of the recommended oil. Reinstall the dipstick.

Note: if the sump is not drained, add about 1 3/4 quarts initially.

13. Place the gear selector in neutral and set the parking brake.

14. Prime the oil pump using the procedure on page 52. Then stop the engine and inspect for leaks.

15. Recheck the oil level on the dipstick and add oil as necessary to bring it to the recommended level on the dipstick.

16. Dispose of used filter and oil properly.

Oil pump priming

This priming procedure must be performed whenever the oil hose connection between the oil tank and pump inlet has been disconnected.

1. Clamp or pinch off the vent line approximately 2" from the oil tank, between the end of the oil tank vent fitting and the vent line's pressure relief slit.

2. Run the engine for 10-20 seconds.

3. Remove the vent line clamp. If the line is bled properly, you should hear a rush of air, indicating that the line is properly primed and ready for operation. If you do not hear air, the line has not bled, and you'll need to repeat the priming procedure.

MAINTENANCE AND LUBRICATION

Engine cooling system

Radiator coolant level

To ensure that the coolant maintains its ability to protect the engine, we recommend that the system be completely drained every two years and a fresh mixture of antifreeze and water added. recommends the use of premium 60/40 anti-freeze/coolant or a 50/50 mixture of high quality aluminum compatible anti-freeze/coolant and distilled water. premium 60/40 is already premixed and ready to use. Do not dilute with water.

•
Note:

Always follow the manufacturer's mixing recommendations for the freeze protection required in your area.

Any time the cooling system has been drained for maintenance or repair, replace the coolant. If the recovery bottle has run dry, the level in the radiator should be inspected. Add coolant as needed.

WARNING

Escaping steam can cause severe burns. Never remove the pressure cap while the engine is warm or hot. Always allow the engine to cool before removing the pressure cap.

1. To access the radiator pressure cap, open the front box lid and pull open the access door.
2. Remove the pressure cap.
3. Using a funnel, slowly add coolant through the radiator filler neck.
4. Reinstall the pressure cap, secure the access door and close the box.

Note: use of a non-standard pressure cap will not allow the recovery system to function properly. Contact your dealer for the correct replacement part.

MAINTENANCE AND LUBRICATION

Engine cooling system

Radiator coolant level

The recovery bottle is located on the left side of the machine. To access the recovery bottle, remove the left side panel .

Maintain the coolant level between the minimum and maximum marks on the bottle (when the fluid is cool). Add coolant as needed.

Cooling system operation

The engine coolant level is controlled or maintained by the recovery system. The recovery system components are the recovery bottle, radiator filler neck, radiator pressure cap and connecting hose.

As coolant operating temperature is increase, the expanding (heated) excess coolant is forced out of the radiator, past the pressure cap, and into the recovery bottle. As engine coolant temperature decreases, the contracting (cooled) coolant is drawn back up from the tank, past the pressure cap, and into the radiator.

Note:

some coolant level drop on new machines is normal, as the system is purging itself of trapped air. Observe coolant levels and maintain as recommended by adding coolant to the recovery bottle.

Auxiliary brake

The auxiliary brake system is intended to be used as a backup for the main brake system. Should the main system fail, the rear brake can be activated by depressing the foot pedal on the inside of the right footrest. The hydraulic auxiliary brake system requires no adjustment.

Note: since this a rear brake only, it will not be as effective as the all-wheel single lever system.

Steering assembly

The steering assembly of the ATV should be checked periodically for loose nuts and bolts. If loose nuts and bolts are found, see your dealer for service before operating the vehicle.

Toe alignment



WARNING

Severe injury or death can result from improper toe alignment and adjustment. Do not attempt to adjust tie rod alignment. All tie rod adjustments should be performed by an authorized dealer.

MAINTENANCE AND LUBRICATION

Use the following procedure to check the toe alignment of the vehicle. The recommended toe alignment is 1/8" to 1/4" toe out.

1. Set the handlebars in a straight-ahead position.

Note: the steering frog can be used as an indicator of whether the handlebars are straight. The frog should always point straight back from the steering post.

2. Place stands (1) in front of the vehicle, perpendicular to the rear tires. See illustration.

3. tie an elastic string around the stands, making sure the string just touches the side surface of the rear tires on each side of the vehicle and goes around the stands in front of the vehicle(2).

4. Measure the distance from the string to the rim at the front and rear of the front rim(3). Rear measurement should be 1/16" -1/8" (.2 to .3 cm) more than the front measurement.

Note: if you discover improper alignment, see your dealer for service

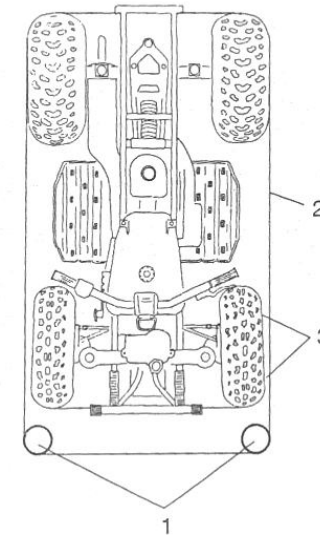

⚠ Warning

Operating your ATV with worn tires, improperly inflated tires, non-standard tires or improperly installed tires will affect vehicle handling and could cause an accident resulting in serious injury or death.

Maintain proper tire pressure as described on the decal on your ATV and in the owner's manual.

Always use original equipment size and type when replacing tires. Make sure the wheels are installed properly.

Always replace tires when the tread depth measures 1/8" (.3 cm) or less..

Tire Tread Depth

Always replace tires when tread depth is worn to 1/8" (.3 cm) or less. See illustration.

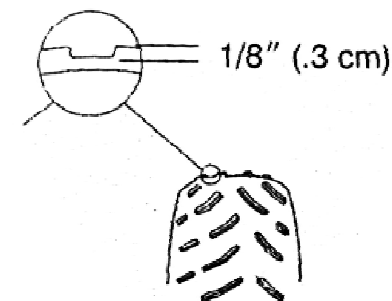

MAINTENANCE AND LUBRICATION

Front wheel hub tightening

Front wheel bearing tightness and spindle nut retention are critical component operations. All service must be performed by your authorized dealer.

Wheel removal

1. Stop the engine, place the transmission in PARK and lock the parking brake.
2. Loosen the wheel nuts slightly.
3. Elevate the side of the vehicle by placing a suitable stand under the footrest frame
4. Remove the wheel nuts and remove the wheel.

Wheel installation

1. Place the transmission in PARK and lock the parking brake.
2. Place the wheel on the wheel hub with the valve stem toward the outside and the rotation arrows on the tire pointing toward forward rotation.
3. Install the wheel nuts and finger tighten.
4. Lower the vehicle to the ground.
5. Torque the wheel nuts to specification

WARNING

Improperly installed wheels can adversely affect tire wear and vehicle handling, which can result in serious injury or death. Always ensure that all nuts are torqued to specification. Do not service axle nuts that have a cotter pin installed. See your dealer.

Wheel nut torque specifications

Check the wheel nut torques occasionally and when they've been loosened for maintenance service.

Item	Specification
Front wheel nuts	27 ft. lbs. (37 Nm)
Rear wheel nuts	27 ft. lbs. (37 Nm)

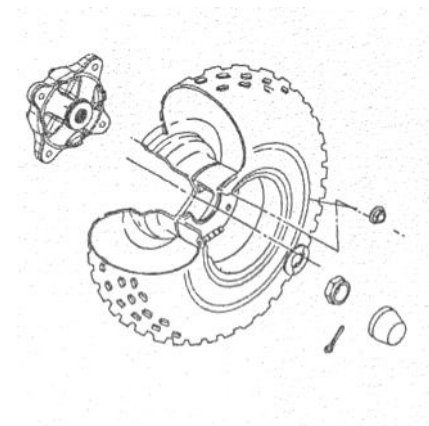

MAINTENANCE AND LUBRICATION

Filter Systems

Air filter Service

1. Remove the seat, release the air box cover clips, and remove the air box cover.
2. Loosen the clamp and remove the filter.
3. Remove the fabric type pre-filter from the main filter. Wash the pre-filter in soapy water, then rinse and let dry.
4. Reinstall the pre-filter over the main filter, (Replace the main filter if needed)
5. Reinstall the filter into the air box and tighten the clamp. Do not over tighten the clamp, as filter damage could occur.
6. Reinstall the air box cover and the seat.

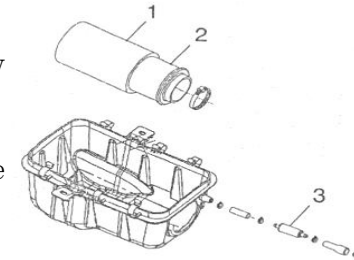

Lights

When servicing a halogen lamp, don't touch the lamp with bare fingers. Oil from your skin leaves a residue, causing a hot spot that will shorten the life for lamp

⚠ WARNING: Poor lighting while driving can result in severe injury or death. Headlight and taillight lenses become dirty during normal operation. Wash the headlights frequently to maintain lighting quality.

Hot components can cause serious burns to skin. Allow lamps to cool before servicing.

Headlight lamp replacement

1. Remove the two screws on the lower front corners of the headlight pod.
2. Remove the screw from the rear of the pod.
3. Lift the pod slightly while depressing the tabs at the rear of the pod.
4. Lift the pod cover and disconnect the speedometer harness from the speedometer.
5. Unplug the headlamp from the wiring harness.
6. Turn the lamp counterclockwise to remove it.
7. Apply dielectric grease to the socket and install the new lamp

MAINTENANCE AND LUBRICATION

NOTE: Make sure the tab on the lamp locates properly in the housing.

8. Reassemble the pod.

High Beam Adjustment

The headlight beam can be adjusted slightly upward or downward.

Use the following procedure to make the adjustment.

1. Position the vehicle on a level surface with the headlight approximately 25ft. (7.6m) from a wall.
2. Measure the distance from the floor to the center of the headlight and make a mark on the wall at the same light.
3. Start the engine and turn the headlight switch to high beam.
4. Observe the headlight aim on the wall. The most intense part of the headlight beam should be two inches (5.1cm) below the mark on the wall.

NOTE: include rider weight on the seat when measuring.

5. The adjustment knob is located the right side of the headlight pod. Adjust the beam to the desired position by turning the knob either clockwise or counterclockwise.

Low Beam Adjustment

The low beam can be adjusted slightly upward or downward.

1. Loosen the Phillips screw located at the rear of the headlamp.
2. Tilt the headlamp upward or downward.
3. Tighten the screw.

Lower Headlamp Removal/Installation

1. Turn the back of the headlight harness counterclockwise and pull the harness assembly away from the headlight assembly.
2. Remove the headlamp and install the new headlamp.
3. Reinstall the harness assembly into the headlight assembly
4. Turn the headlight harness clockwise to secure the headlamp

MAINTENANCE AND LUBRICATION

Taillights /brake light /work light lamp replacement

1. Remove the harness connector (1) from the back of the light assembly.
2. Turn the lamp (2) counterclockwise to remove it.
3. Apply dielectric grease to the socket and install the new lamp.
4. Reinstall the harness connector.
5. Test the light for proper operation.

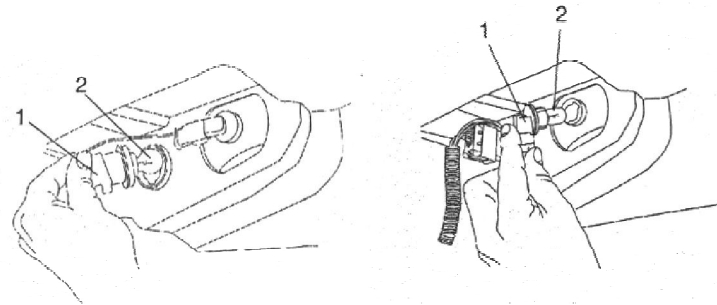

Spark Plug

Always use the spark plugs recommended for your ATV.

CAUTION

Using non-recommended spark plugs can result in serious engine damage. Always use -recommended spark plugs.

Spark plug condition is indicative of engine operation. The spark plug firing end condition should be read after the engine has been warmed up and the vehicle has been driven at higher speeds. Immediately check the spark plug for correct color

WARNING

A hot exhaust system and engine can cause serious burns. Wear protective gloves when removing a spark plug for inspection.

1. Normal

The normal insulator tip is gray, tan or light brown. There will be few combustion deposits. The electrodes are not burned or eroded. This indicates the proper type and heat range for the engine and the service.

NOTE: The tip should not be white. A white insulator tip indicates overheating, caused by use of an improper spark plug or incorrect carburetion adjustment.

MAINTENANCE AND LUBRICATION

2. Wet Fouled

The wet fouled insulator tip is black. A damp oil film covers the firing end. There may be a carbon layer over the entire nose. Generally, the electrodes are not worn. General causes of fouling are excessive oil, use of non-recommended oil, improper use of the choke, or incorrect carburetion adjustments.

Spark Plug Removal and Replacement

1. remove the spark plug cap
2. Using the special wrench provided in tool pouch, rotate the spark plug counterclockwise to remove.
3. Reverse the procedure for spark plug installation, using the recommended spark plug. Torque to 18 ft-lb. (24 Nm).

Vehicle Immersion

CAUTION

If your vehicle becomes immersed, major engine damage can result if the machine is not thoroughly inspected. Take the vehicle to your dealer before starting the engine.

If it is impossible to take your ATV to a dealer before starting it, follow the steps outlined below.

1. Move the ATV to dry land or at the very least, to water below the footrests.
2. check the air box for any water and dry it if water is present, filter replacement is required if water intrusion is evident.
3. turn the fuel valve off.
4. remove the spark plug
5. loosen the carburetor drain screw.
6. turn the engine over several times using the electric start.
7. dry the spark plug and reinstall, or replace it with a new plug.
8. tighten the carburetor drain screw.
9. turn the fuel valve on
10. attempt to start the engine. If necessary, repeat the drying procedure.

11. take the ATV to your dealer for service as soon as possible, whether you succeed in starting it or not.

NOTE: if water has been ingested into the PVT, follow the procedure on page 99 for drying

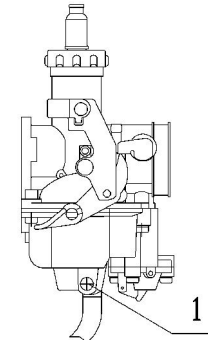

MAINTENANCE AND LUBRICATION

Battery

Your ATV may have either a sealed battery, which requires little maintenance, or a conventional battery. A sealed battery can be identified by its flat covers on the top of the battery. A conventional battery has six filter caps on the top of the battery.

Always keep battery terminals and connections free of corrosion. If cleaning is necessary, remove corrosion with a stiff wire brush. Wash with a solution of one tablespoon baking soda and one cup of water. Rinse well with tap water and dry off with clean shop towels. Coat the terminals with dielectric grease or petroleum jelly. Be careful not to allow cleaning solution or tap water into a conventional battery.

WARNING

Battery electrolyte is poisonous. It contains sulfuric acid. Serious burns can result from contact with skin, eyes, or clothing.

Antidote:

External: Flush with water

Internal: Drink large quantities of water or milk. Follow with milk of magnesia, beaten egg, or vegetable oil. Call physician immediately.

Eyes : Flush with water for 15 minutes and get prompt medical attention.

Batteries produce explosive gases,. Keep sparks, flame, cigarettes, ets. Away. Ventilate when charging or using in an enclosed space. always shield eyes when working near batteries. KEEP OUT OF REACH OF CHILDREN.

Battery Removal

1. Disconnect the hold-down strap holding the battery in position, and remove battery cover.
2. On conventional batteries, remove the battery vent tube.
3. Disconnect the black (negative) battery cable next.
4. Disconnect the red (positive) battery cable next.
5. Lift the battery out of the ATV. Be careful not to tip a conventional battery sideways, which could spill electrolyte.

CAUTION

If electrolyte spills, immediately wash it off with a solution of one tablespoon baking soda and one cup water to prevent damage to the vehicle.

MAINTENANCE AND LUBRICATION

BATTERY INSTALLION

1. Set the battery in the battery holder.
2. With conventional batteries, install the battery vent tube (sealed batteries do not have a vent tube).

NOTE: the vent tube must be free of obstructions and securely installed. If not , battery gases could accumulate and cause an explosion. The tube should be routed away from the frame and body to prevent corrosion. Avoid skin contact with electrolyte, which can cause severe burns.

3. First connect and tighten the red(positive) cable.
4. Second connect and tighten the black(negative) cable.
5. Reinstall the battery cover and attach the hold-down strap.
6. Verify that cables are properly routed.

NOTE: When installing a new battery, make sure it's fully charged prior to its initial use. Using a new battery that has not been fully charged can damage the battery and result in a shorter life. It can also hinder vehicle performance.

Battery Storage

When the vehicle is placed in storage for three months or more, the battery should be removed, stored out of the sun in a cool, dry place and tested monthly. Before reusing ,take the battery to your dealer for testing and recharge.

Power plug leads may need to be bent down so that the battery cover can be installed.

Replenishing Battery fluid (Conventional Battery)

A poorly maintained battery will deteriorate rapidly. Check the battery fluid level often. The fluid level should be kept between the upper and lower level marks (1).

To refill use only distilled water. Tap water contains minerals that are harmful to a battery.

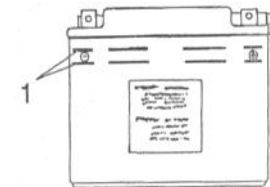

MAINTENANCE AND LUBRICATION

WARNING

Improperly connecting or disconnecting battery cables can result in an explosion and cause serious injury or death. When removing the battery, always disconnect the negative (black) cable first. When reinstalling the battery, always connect the negative (black) cable last.

Battery Charging (Sealed Battery)

The following battery charging instruction apply only to the installation of a YUASA activated, sealed battery. Read all instructions before proceeding with the installation of this battery.

The YUASA activated, sealed battery is already filled with electrolyte and has been sealed and fully charged at the factory. Do not ever pry the sealing strip off or add any other fluid to this battery.

The single most important thing to maintaining a sealed battery is to keep it fully charged. Since the battery is sealed and the sealing strip cannot be removed, you must use a voltmeter or multimeter to measure DC voltage.

Stabilize the Fuel

Fill the fuel tank. Add Carbon Clean Fuel Treatment or Fuel Stabilizer. Follow the instruction on the container for the recommended amount. (Carbon clean will also reduce the possibility of bacterial growth in the fuel system.) allow 15-20 minutes of operation for the stabilizer to disperse through the fuel in the tank and carburetor.

Turn the fuel valve off and drain the carburetor bowl

Oil and Filter

Warm the engine and change the oil and filter.

Air Filter/ Air Box

Inspect and clean or replace the pre-cleaner and air filter, Clean the air box and drain the sediment tube.

Breather Filter

Inspect and clean or replace the breather filter.

MAINTENANCE AND LUBRICATION

Cleaning and Storage

Storage Tips

Fluid Level

Inspect the following fluid level and change if necessary: front and rear gearcases; transmission and brake fluid (change every two years or as required if fluid looks dark or contaminated).

Fog the engine

1. Remove the spark plug and add 2-3 tablespoons of Premium 4 Synthetic 0W40 engine oil. To access the plug hole, use a section of clear 1/4" hose and a small plastic squeeze bottle filled with the pre-measured amount of oil.

NOTE: Do this carefully! If you miss the plug hole, oil will drain from the spark plug cavity into the hole at the front of the cylinder head, and appear to be an oil leak.

2. Reinstall the spark plug. Torque to 18ft, lbs. (24Nm)

3. Apply dielectric grease to the inside of the spark plug cap and install the cap onto the plug.

4. Turn the engine over several times. Oil will be forced in and around the piston rings and ring lands, coating the cylinder with a protective film of fresh oil.

Alternative to Using Fogging Oil

If you choose not to use Fogging Oil, perform the following procedure.

1. Treat the fuel system with Carbon Clean, following the instruction on the can. Run the engine for several minutes so the Carbon Clean reaches the carburetor. Turn the engine off.

2. Support the front end of the machine so the engine is level or tilted slightly rearward.

3. Remove the spark plug. Rotate the piston to BDC and pour approximately two ounces of recommended oil into the cylinder.

4. Reinstall the spark plug and torque to 18 ft. lbs (24Nm)

5. Apply dielectric grease to the inside of the spark plug cap and install the cap onto the plug.

6. Turn the engine over several times to ensure coverage of piston rings, cylinder walls and crankshaft bearings.

7. If fuel system additive is not used, fuel tank, fuel lines, and carburetor should be completely drained of gasoline. To eliminate any fuel remaining in the carburetor, run the engine until it stops.

MAINTENANCE AND LUBRICATION

Cleaning and Storage

Inspect and Lubricate

Inspect all cables and lubricate. Follow lubrication guidelines in the Maintenance Section of the service or owner's manual to completely grease and lubricate the entire vehicle with Premium All Season Grease.

Storage Tips

Battery Maintenance (Conventional)

Remove the battery and add distilled water to the proper level. Do not use tap water, which may contain minerals the reduce battery life.

Apply dielectric grease to the terminal bolts and terminals. Charge the battery at 1.4 amps or less until the specific gravity of each cell is 1.265 or greater. Store the battery in a cool, dry place.

Charge can be maintained easily by using Battery Tender TM charge (PN 2871076) or by charging about once a month to make up for normal self-discharge. Battery Tender TM can be left connected during the storage period, and will automatically charge the battery if the voltage drops below a pre-determined point. Check the fluid level monthly.

Battery Maintenance (Sealed)

Remove the battery and recharge it as outlined on page 102. store the battery in a cool ,dry place.

Engine Anti-Freeze

Test engine coolant strength and change if necessary. Coolant should be replaced every two years.

Storage Area/Covers

Set the tire pressure and safely support the ATV with the tires 1-2' off the ground. Be sure the storage area is well ventilated, and cover the machine with a genuine ATV cover.

NOTE: Do not use plastic or coated materials. They do not allow enough ventilation to prevent condensation, and may promote corrosion and oxidation.

MAINTENANCE AND LUBRICATION

Chrome Wheel Care (if equipped)

Proper maintenance will protect chrome wheels from corrosion, preserve wheel life and ensure a “like new” appearance for many year.

1. Wash chrome rims frequently. Use a mild detergent to remove any salt, dirt, mud or grime. Never use abrasive cleaners on plated or painted surfaces.
2. Polish the clean chrome wheels periodically. Use an automotive grade chrome polish.
3. Routinely and liberally apply a weather resistant wax to each polished chrome wheel. Choose a product suitable for chrome finishes. Read and follow the product labels and instructions.
4. Chrome wheels exposed to road salt (or salt in the air in coastal areas) are more susceptible to corrosion if not properly cleaned. Clean chrome wheels more often if they're exposed to salt or other corrosive elements.

Removing Corrosion

If light rust is found on the chrome finish, use steel wool(# 0000-0TT grade) to remove it. Gently rub the affected areas with the steel wool until the corrosion has been removed. Clean and polish the wheel as outlined above.

Transporting the ATV

Follow these procedures when transporting the vehicle.

1. Turn off the engine and remove the key to prevent loss during transporting.
2. Place the transmission in PARK and lock the park brake.
3. Turn the fuel valve off and be sure the fuel cap, oil cap and seat are installed securely.
4. Always tie the frame of the ATV to the transporting unit securely with suitable straps or rope. Do not attach tie strap to the front A-arm bolt pockets.

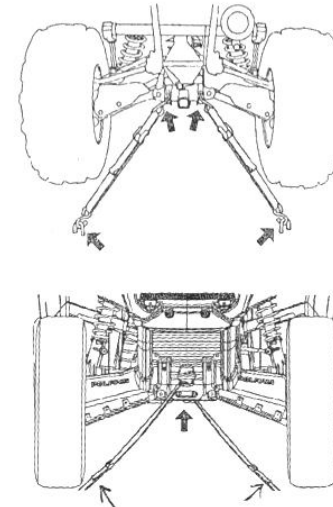

ADJUSTMENTS

Camber and Caster

The camber and caster are non-adjustable.

Rear Spring

the rear shock absorber spring is adjusted by rotating the adjuster(1) either clockwise or counterclockwise to increase or decrease spring tension.

NOTE: Accessory springs are available through your dealer.

Handlebars

The handlebars can be adjusted for rider preference.

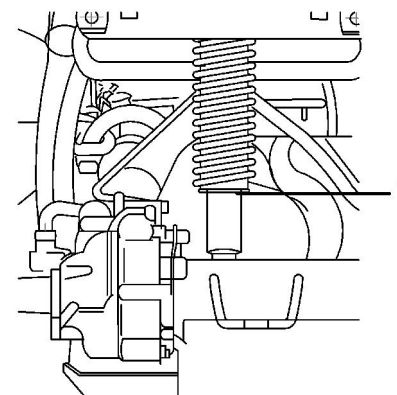

WARNING

Improper adjustment of the handlebars or incorrect torquing of the adjuster block tightening bolts can cause limited steering or loosening of the handlebars, resulting in loss of control and possible serious personal injury or death. Follow the adjustment procedure exactly, or see your dealer for service.

1. Locate handlebar bolts (1) by removing the upper headlight pod.
2. Loosen the four bolts.
3. Adjust the handlebar to the desired height. Be sure the handlebars do not contact the gas tank or any other part of the machine when turned fully to the left or right.
4. Torque the front two bolts to 10-12 ft.lbs. (14-17 Nm), then torque the rear two bolts. A gap of up to 1/8" will remain at the rear bolts.

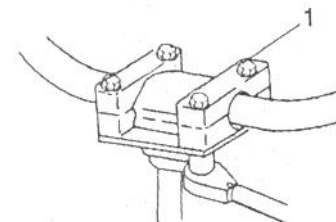

ADJUSTMENTS

Carburetor/Idle RPM

Your ATV is calibrated at the factory for optimal performance at altitudes ranging from zero to 6,000 feet (1800m) and temperatures of +40 degrees F. (4 degree C.) or higher. Above 6,000 feet (1800m) the engine air/fuel mixture becomes overly rich and the engine loses approximately 3% of its power for each 1000-foot (308m) increase in elevation. Although this power cannot be regained, adjustments to the carburetor and drive system can be made to allow more efficient operation. Optional jets, available from your dealer, are required for operation above 6,000 feet and temperatures below +40 degrees F. (4 degree C.)

If the engine idle speed is not satisfactory, and all other conditions are favorable, the carburetor can be adjusted.

1. Warm up the engine by running the vehicle for approximately five minutes.
2. Place the transmission in gear with the parking brake applied.
3. adjust the carburetor idle screw (1) either in or out until the desired idle RPM is reached. Turn the screw in (clockwise) will raise RPM. Turning the screw out (counterclockwise) will lower RPM

NOTE: Continuous operation of the engine without proper jetting when required can cause poor performance, overheating or engine damage. See your dealer for more information about jetting the ATV for condition in your area.

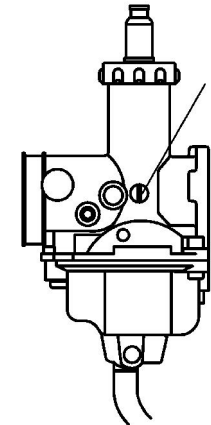

Throttle Cable Freeplay

Throttle cable freeplay is adjusted at the handlebar.

1. Slide the boots (1) off the inline cable adjuster sleeve (2). Loosen the adjuster locknut (3).
2. Turn the adjuster until 1/16" to 1/8" freeplay is achieved at the thumb lever.

NOTE: While adjusting freeplay, be sure to flip the throttle lever back and forth.

3. Tighten the locknut and slide the boots over the cable adjuster until they touch at the midpoint of the adjuster.

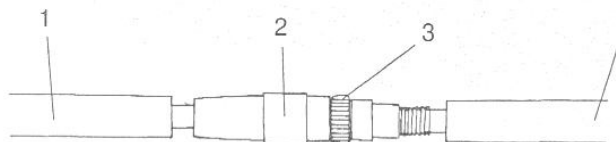

TROUBLESHOOTING

Drive Belt and Cover Problems

Drive Belt and Cover Problems	Solution
Driving the ATV onto a pickup or tall trailer in high range	When starting out on an incline, use low range or dismount the ATV (after first applying the park brake)
Driving at low RPM or low ground speed (at approximately 3-7 MPH)	Drive at a higher speed or use low range more frequently. The use of low range is highly recommended for cooler PVT operating temperatures and longer component life.
Insufficient warm-up of ATVs exposed to low ambient temperatures	Warm the engine at least 5 minutes. With the transmission in neutral, advance the throttle to about 1/8 throttle in short bursts, 5 to 7 times. The belt will become more flexible and prevent belt burning.
Slow and easy clutch engagement	Use the throttle quickly and effectively for efficient engagement
Towing/pushing at low RPM/low ground speed	Use low range only
Utility use/plowing snow, dirt, etc.	Use low range only
Stuck on mud or snow	Shift the transmission to low range, land carefully use fast aggressive throttle application to engage clutch.
	WARNING: Excessive throttle may cause loss of control and vehicle overturn.
Climbing over large objects from a stopped position.	Shift the transmission to low range, land carefully use fast aggressive throttle application to engage clutch.
	WARNING: Excessive throttle may cause loss of control and vehicle overturn.
Belt slippage from water or snow ingesting into the PVT system.	Shift the transmission to neutral. Using the throttle, vary the engine RPM from idle to full throttle. Repeat several times as required. During this procedure, the throttle should not be held at the full position for more than 10 seconds. Clutch seals should be inspected for damage if repeat leaking occurs
Clutch malfunction	Contact your dealer for inspection of clutch component.
Poor engine performance	Check for fouled plugs or foreign material in gas tank, fuel lines, or carburetor, contact your dealer for service.

TROUBLESHOOTING

Contact your dealer for service if you're unable to identify solutions using the following charts.

Engine Doesn't Turn Over

Possible cause	Solution
Tripped circuit breaker	Reset the breaker
Low battery voltage	Recharge battery to 12.5
Loose battery connections	Check all connections and tighten
Loose solenoid connections	Check all connections and tighten

Engine turns over, fails to start

Possible cause	Solution
Out of fuel	Refuel
Clogged fuel valve or filter	Inspect and clean or replace
Water is present in fuel	Drain the fuel system and refuel
Fuel valve is turned off	Turn the fuel valve on
Old or non-recommended fuel	Replace with new fuel
Fouled or defective spark plug(s)	Inspect, clean and /or replace spark plugs
No spark to spark plug	Inspect plug(s), verify stop switch is on
Crankcase filled with water or fuel	Immediately see your dealer
Overuse of choke	Inspect, clean and/or replace spark plugs
Clogged fuel filter	Replace the filter
Low battery voltage	Recharge battery to 12.5 VDC
Mechanical failure	See your dealer

Engine Pings or knocks

Possible cause	Solution
Poor quality or low octane fuel	Replace with recommended fuel
Incorrect ignition timing	See your dealer
Incorrect spark plug gap or heat range	Set gap to specs or replace plugs

TROUBLESHOOTING

Engine Backfires

Possible Cause	Solution
Weak spark from spark plugs	Inspect, clean and /or replace spark plugs
Incorrect spark plugs gap or heat range	Set gap to specs or replace plugs
Old or non-recommended fuel	Replace with new fuel
Incorrectly installed spark plugs wires	See your dealer
Incorrect ignition timing	See your dealer
Mechanical failure	See your dealer

Engine runs irregularly, stalls or misfires

Possible Weak Spark Cause	Solution
Fouled or defective spark plugs	Inspect, clean and/or replace spark plugs
Worn or defective spark plug wires	See your dealer
Incorrect spark plug gap or heat range	Set gap to specs or replace plugs
Loose ignition connections	Check all connections and tighten
Water present in fuel	Replace with new fuel
Low battery voltage	Recharge battery to 12.5 VDC
Kinked or plugged fuel vent line	Inspect and replace
Incorrect fuel	Replace with recommended fuel
Clogged air filter	Inspect and clean or replace
Reverse speed limiter malfunction	See your dealer
Electronic throttle control malfunction	See your dealer
Other mechanical failure	See your dealer
Low or contaminated fuel	Add or change fuel, clean the system
Low octane fuel	Replace with recommended fuel
Clogged fuel filter	Replace filter
Incorrect jetting	See your dealer
Overuse of choke	Inspect, clean and/or replace spark plugs
Fuel is very high octane	Replace with lower octane fuel
Incorrect jetting	See your dealer

TROUBLESHOOTING

Engine Stops or Loses Power

Possible Cause	Solution
Out of fuel	Refuel
Kinked or plugged fuel vent line	Inspect and replace
Water present in fuel	Replace with new fuel
Overuse of choke	Inspect, clean and /or replace spark plugs
Fouled or defective spark plugs	Inspect, clean and/or replace spark plugs
Worn or defective spark plug wires	See your dealer
Incorrect spark plug gap or heat range	Set gap to specs or replace plugs
Loose ignition connections	Check all connections and tighten
Low battery voltage	Recharge battery to 12.5 VDC
Incorrect fuel	Replace with recommended fuel
Clogged air filter	Inspect and clean or replace
Reverse speed limiter malfunction	See your dealer
Electronic throttle control malfunction	See your dealer
Other mechanical failure	See your dealer
Overheated engine	Clean radiator screen and core
	Clean engine exterior
	See your dealer

Engine Overheating

Possible Cause	Solution
Debris lodged screen	Remover and clean the screen. Pull on the top portion of the screen, then remove the lower portion.
Plugged radiator	Use a garden hose to flush any debris from the radiator fins. NOTE: high pressure washers can deform the radiator fins and reduce cooling efficiency.

SPECIFICATIONS

Vehicle Specification:

ITEM	(ITEM/ Measurement)	(Specification)	(ITEM/ Measurement)	(Specification)
Vehicle Specification	L×W×H	1850×1030×1130mm	Wheelbase	1160mm
	Whell Track (F/R)	930/860mm	Min. ground clearance	155mm
	Dry weight	240kg	Load capacity	100kg
	Max. speed	65km/h	Break type (F/R)	Drum/Drum
	Brake operation(F/R)	Handle / Kick	whell rim(F/R)	steel rim / steel rim
	Tyre size (F/R)	23×8-10	tire pressure (F/R)	5±0.4psi/5±0.4 psi
		22×12-10		
	Transmission mode	axis	Fuel tank capacity	11L
Min. turning radius	2900mm	Height of seats	820mm	

Engine Specification

ITEM	(ITEM/ Measurement)	(Specification)	(ITEM/ Measurement)	(Specification)
Engine Specification	Model	167MM	Bore×Stroke	Φ67×65mm
	Type	single cylinder, oil-cooling, four-stroke	Displacement	229.2ml
	Compression proportion	10:01	standardization power and rotate speed	11.5KW/6500r/min
	Max power and rotate speed	12KW/6500r/min	Max torque and rotate speed	17.5N.m/5500r/min
	Min. steady idling speed	1400r/min ± 100	Min. Fuel Consumption	354g/kW · h
	Fuel type	90#	Lubrication	press splash
	Lube type	SAE 15W/40	Clutch type	Manual Wet Multi-Plate

WARRANTY

KANGCHAO GROUP (USA), INC-EMISSION CONTROL SYSTEM WARRANTY YOUR WARRANTY RIGHTS AND OBLIGATIONS

The emission control system warranty period for this vehicle begins on the date the vehicle is delivered to the first purchaser other than an authorized dealer, or the date it is first used as a demonstrator, lease, or company vehicle, whichever comes first and continues for 30 months after that date, or 5,000km, whichever comes first, provided there has been no abuse, neglect or improper maintenance of your vehicle. Where a warrantable condition exists, the Distributor will repair your vehicle at no cost to you, including diagnosis, parts and labor. If an emission-related part on your vehicle is defective, the part will be repaired or replaced by the Distributor. This is your emission control defects warranty.

OWNER' S WARRANTY RESPONSIBILITIES

As the vehicle owner, you are responsible for the performance of the required maintenance. You should maintain a record of all maintenance performed on your vehicle and retain all receipts covering maintenance on your vehicle. You may not be denied a warranty claim solely because of your failure to ensure the performance of all scheduled maintenance or lack of maintenance records or receipts. You are responsible for presenting your vehicle to an authorized dealer as soon as a problem exists. The warranty repairs should be completed in a reasonable amount of time, not to exceed 30 days.

As the vehicle owner, you should be aware that you may be denied your warranty coverage if your vehicle or a part has failed due to abuse, neglect, improper maintenance, or unapproved modifications.

WARRANTY COVERAGE

The Distributor warrants that each new 2008 and later vehicle:

- is designed, built, and equipped so as to conform at the time of initial retail purchase with all applicable regulations of the United States Environmental Protection Agency, and the California Air Resources Board; and
- is free from defects in material and workmanship which cause such vehicle to fail to conform with applicable regulations of the United States Environmental Protection Agency or the California Air Resources Board for the periods specified above.

Your emission control system warranty covers components whose failure would increase an engine' s emission, including eleGLDonic controls, fuel injection system, carburetor, the ignition system, catalytic converter, or any other system utilized in this vehicle to control emission if it is originally equipped. Also included may be hoses, connectors and other emissionrelatedassemblies. Replacing or repairing other components (including parts, labor, and other costs) not covered by this emission control system warranty or the standard warranty is the responsibility of the owner.

WARRANTY

Coverage of repairs under this warranty applies only when repairs are completed at an authorized dealer or repair facility. The Distributor will not cover repairs performed outside of an authorized dealer or repair facility, except in an emergency situation. The use of replacement parts not equivalent to the original parts may impair the effectiveness of your vehicle's emission control system. If such a replacement part is used and an authorized dealer determines it is defective or causes a failure of a warranted part, your claim for repair to bring your vehicle into compliance with applicable standards may be denied.

If an emergency situation exists when a warranted part or a dealer is not reasonably available to the owner, repairs may be performed at any available service establishment, or by the owner, using any replacement part. The Distributor shall reimburse the owner for the expenses, including diagnostic charges, not to exceed the Distributor's suggested retail price for all warranted parts replaced and labor charges based on the Distributor's recommend time allowance for the warranty repair and the geographically appropriate hourly labor rate. The owner may reasonably be required to keep receipts and failed parts in order to receive compensation.

This Emission Control System Warranty is in addition to the standard Limited Warranty.

EXCLUSIONS AND LIMITATIONS

This warranty does not cover the following:

- Failures or malfunctions of the emission control systems caused by abuse, alteration, accident, misuse, the use of leaded gasoline.
- Replacement of expendable maintenance items unless they are original equipment defective in material or workmanship under normal use, and the first required replacement interval for the item has not been reached. Expendable maintenance items include but not limited to spark plugs, filters, coolant, lubricants, gaskets, hoses, and belts.
- Replacements of parts and other services and adjustments for required maintenance.
- Any vehicle equipped with an odometer or hour meter where the reading is altered so that actual mileage cannot be readily determined.

Repairs or replacements as a result of:

- o Accident
- o Misuse
- o Use of replacement parts or accessories not conforming to the original specifications which adversely affect performance

WARRANTY

- Physical damage, corrosion, or defects caused by fire, explosions or similar causes beyond the control of the Distributor.

- Failures not caused by a defect in material or workmanship.

Use of the vehicle in any type of competitive racing or related events immediately and completely voids this and all other warranties.

LIMITED LIABILITY

The liability of the Distributor under this Emission Control System Warranty is limited solely to the remedying of defects in material workmanship by an authorized dealer at its place of business during customary business hours. This warranty does not cover inconvenience or loss of use of the vehicle or transportation of the vehicle to/from the authorized dealer. The Distributor is not liable to any person for incidental, consequential or special damages of any description, whether arising out of express or implied warranty or any other contract, negligence or other tort or otherwise.

No express emission control system warranty is given by the Distributor except as specifically set forth herein. Any emission control system warranty implied by law, including any warranty of merchantability or fitness for a particular purpose is limited to the express emission control system warranty terms stated in this warranty. The foregoing statements of warranty are exclusive and in lieu of all other remedies. All express warranties not stated in this warranty are disclaimed. Some states do not allow limitations on how long an implied warranty lasts, so the above limitations may not apply if it is inconsistent with the controlling state law.

No dealer is authorized to modify this Emission Control System Warranty. If you have any questions regarding your warranty rights and responsibilities, you should contact Kangchao Group (USA), Inc. at (626) 961-9016 (or you can write to 15222 Valley Blvd., City of Industry, CA 91746) or the California Air Resources Board, 9528 Telstar Avenue, El Monte, CA 91731 (for California registered vehicles only).